

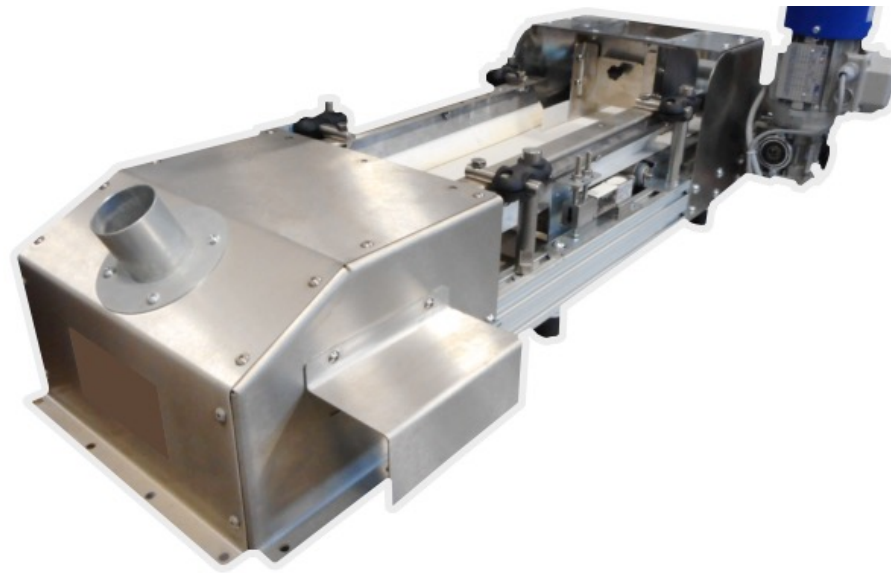

the ideal partner for all handling solutions

definitiveinnovation.com

GRAVIMETRIC BELT FEEDERS «BW» SERIES



Model type	1	7,5	15	25	125	250	800	1600	3200	6500	1300
GS020D	Yellow	Yellow	Yellow								
GS030D		Green	Green	Green	Green						
GR030D		Green	Green	Green	Green						
GR040D			Cyan	Cyan	Cyan	Cyan					
GM060D					Blue	Blue	Blue	Blue			
GM080D						Red	Red	Red	Red		
GL100D							Magenta	Magenta	Magenta	Magenta	
GL120D								Brown	Brown	Brown	Brown

GRAVIMETRIC BELT FEEDERS «BW» SERIES

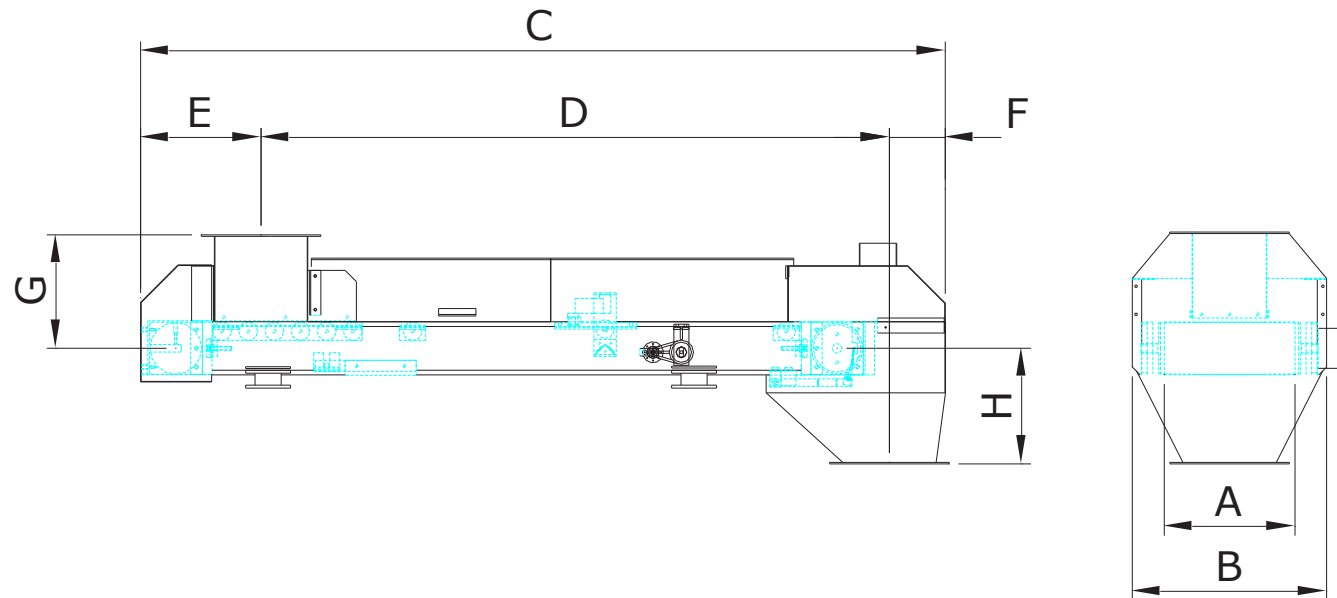

Modello	A	B	C	D	E	F	G
BW025	250	450	1900	1500	250	150	200
BW035	350	550	2300	1800	350	150	300
BW055	550	800	3300	2500	550	250	400
BW080	800	1100	4200	3000	800	400	500
BW120	1200	1500	5200	3500	1200	500	600

GRAVIMETRIC BELT FEEDERS «BW» SERIES

	Fornitura standard	A richiesta
Materiale chassis	A richiesta	Fe 360-Aisi 304
Materiale nastro	pvc	Alimentare, antiusura
Sistema centraggio nastro	Rulli convessi	Dispositivo pneumatico
Sistema tensionamento nastro	manuale	contrappeso
Sistema pulizia nastro	Raschiatori antiusura	Raschiatori PTFE
Sistema di rilevamento peso	Ponte a 2 celle di carico	Versione ATEX zona 2D
Sistema rilevamento velocità	encoder	Versione ATEX zona 2D
Optionals	Vedere documento specifico	

BELT FEEDERS' GRAVIMETRIC CONTROL

Feeder type	Fornitura standard	A richiesta	Fornitura standard	Fornitura standard
G	1	DCG01	7 INC.	<p> painted steel box (AVAILABLE IN SS AISI 304) Line voltage 400VAC 3PH + N + PE painted steel box Line voltage 400VAC 3PH + N + PE Execution for installation in a safe NO ATEX area electric control panel is equipped with: DEFINITIVE INN. dosing management program Historical archive management of production data Touch screen operator interface, Weintek "color with the following operations: set-point entry; entry of specific dosage parameters for each powder, remote assistance; compatible with remote PC supervision SOFTWARE DEFINN 1 SIEMENS PLC series 1200 for the management of dosing and automatic refill loading 24VDC power supply for auxiliaries Automatic / manual disconnectors for dispenser / s Alarm silencing by push button Mushroom emergency STOP button (general) Transformers, disconnectors, fuses and terminal blocks converter / s for on-board machine load cell with Pro-finet I / O protocol </p>
	2	DCG02	10 INC.	
	3	DCG03	10 INC.	
	4	DCG04	15 INC.	
	5	DCG05	15 INC.	
	6	DCG06	15 INC.	
	...	Customized	Customized	
<p>Remote assistance available if required</p>				

BELT FEEDERS' GRAVIMETRIC CONTROL

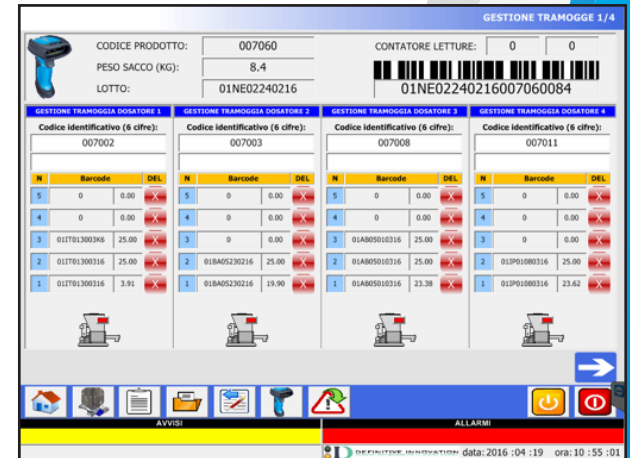
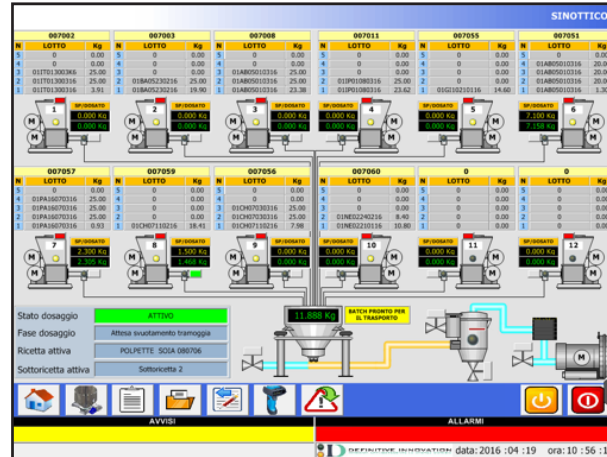
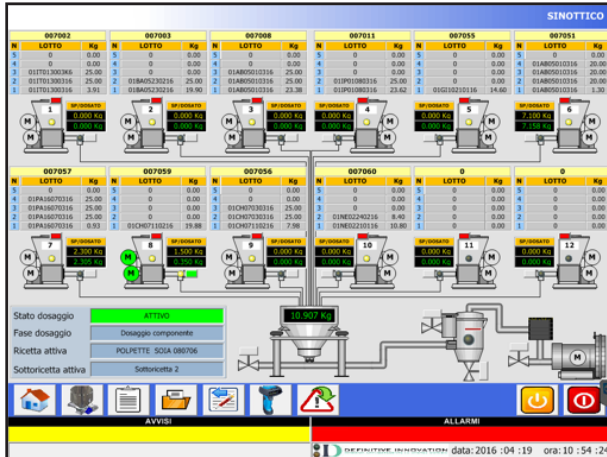

EXAMPLES OF SYNOPTICS

